

Container Labelling Machine

CL 20.2



Application

Front and back labelling of flat shaped containers
Suitable for pharmaceutical applications

Features

- Rigid frame construction
- Very easy to operate
- Low changeover time
- Designed for 20m/minute label dispensing speed
- Label positional accuracy of $\pm 1\text{mm}$
- Synchronisation of speed by means of an encoder
- Servo driven labelling heads
- Spacing & Centering units with opposed side belts
- Slat conveyor with stainless steel structure
- Upper top hold belt to make products stable
- All adjustments are provided with scale
- Touch screen operator interface adjustable for height
- Recipes facility
- Fully enclosed control cabinet

Optionals

- Language options for different countries
- Label break sensor
- Remote Diagnostics
- Password and user log facility

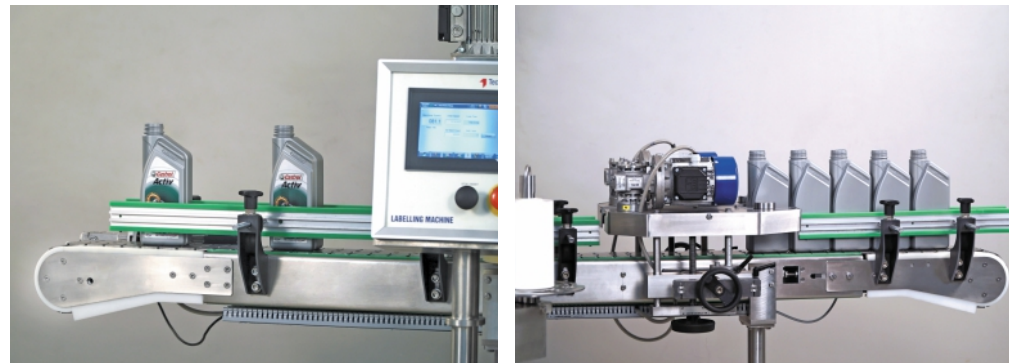

Container Labelling Machine CL 20.2

Technical Specifications

- Label Dispensing Speed : 20 metres / minute
- Accuracy : Label positional accuracy of ± 1 mm
- Power : 4.4 KW, 3 phase, 415 VAC, 50/60 Hz
- Max. Component Height : 300mm (height), 50mm (width)
- Min. Component Height : 50mm
- Min. Label : 30mm (height)
- Max. Label : 250mm (height)
- Media Roll Size : 350mm (diameter) 3" core
- Machine Weight : 700KG

Application Example

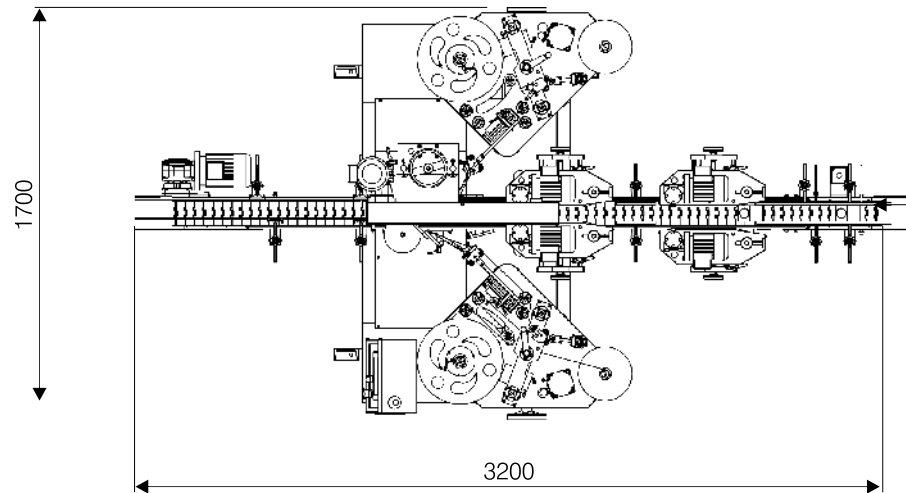

Layout :

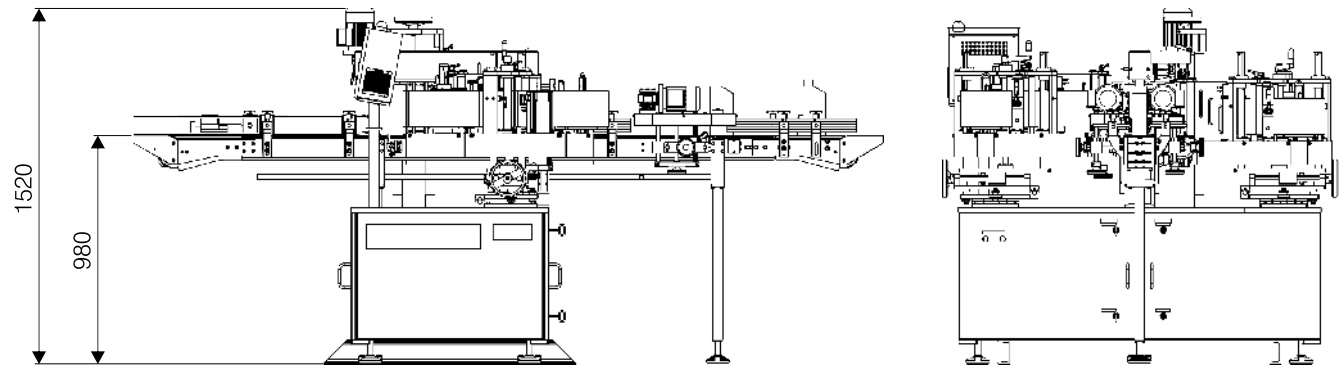

 **Technoshell**
Automations Pvt. Ltd.

G - 49, M.I.D.C., Ambad, Nashik - 422010. INDIA

Ph.: +91 253 6647 300.

Email: info@technoshell.com URL: www.technoshell.com

For Machine Video

